

# Western Communications Co-operative Ltd.

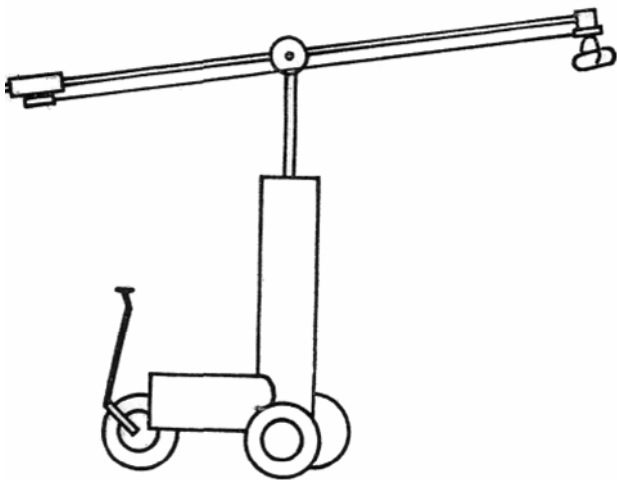

**Annual Report 77-78**

- WESTERN COMMUNICATIONS CO-OP. LIMITED -

ANNUAL REPORT : 1977/8

Locations:

Main office

3 Freyer Street  
North Williamstown, Vic.

Telephone: 397 734-9

Porta Pak Loans

Altona City Library

Telephone:

Staff:

(full time)

Miles Green

Telephone: 397 7349

1977/8

Chairman .. Ivars Avens

Treasurer .. Alan Dyall

Secretary .. Robert Stewart

Directors .. Ted Peck  
Kelvin Lee

## CONTENTS

### AIMS OF CENTRE

1. CHAIRMAN'S REMARKS
  
2. THE LAST TWELVE MONTHS IN RETROSPECT -
  - (a) General operation (staffing)
  
  - (b) Equipment - Purchases  
Robbery
  
  - (c) Borrowings - i. Freyer Street  
ii. Altona Library
  
  - (d) Financial Statement
  
3. THE 1978/9 SUBMISSION
  - THE FUTURE -
    - i. Staff
    - ii. Equipment
    - iii. Mobile Recording Vans
    - iv. New areas of operation

CHAIRMAN'S INTRODUCTION :

The past financial year saw many dramatic moments in the life of the co-operative. The period has been a difficult, though stimulating one, and it has been a privilege for me to be Chairman of the co-operative for the past six months.

It is with pleasure that I present the following report of the co-operatives activities during the financial year - 1977/8.

IVARS AVENS,

Chairman.

AIMS OF WESTERN COMMUNICATIONS CO-OP. LIMITED.

During the last twelve months the centre has steadily moved towards the consolidation and development of three basic principles :

1. To continue and develop an accessibility for the community to video equipment, particularly portapak, at the cheapest rates possible. That the only restriction on access be the membership of the co-operative.
2. To provide and encourage the use of simple, but effective editing systems with reliable performance characteristics. That this editing facility be updated and improved as finance and technology permits.
3. The encouragement of the use of multi-camera television production with the provision of a mobile field recording system. That every effort be made for encouraging its use on a creative as well as technical level.

It is with the above three principles in mind that our purchases and ideas in mind have moved and will continue to aid in community involvement under the most accessible conditions for 1978-9.

#### REVIEW OF THE LAST TWELVE MONTHS

The last financial year of operations of the co-operative has passed with a mixture of outstanding successes together with the not so successful events that we tend to feel are not worthy of a place in our memories.

It is clear however that the co-operative, despite this, has had one of its most successful periods yet; this being based on the number of bookings made through the centre and the number of members enrolled, together, with the new types of associations coming into the centre.

#### LOANS OF EQUIPMENT

The number of loan-outs of equipment is pleasing despite our robbery of nearly all the equipment around Christmas time, 1978. The robbery literally left the cupboard bare and the insurance company delayed payment until May/June of this year causing a huge drop in bookings. The centre's viability was really under threat, but due the efforts of many, and in particular John Conte, we managed to survive.

The graph indicates good results for most of the budgeted period with a large increase in June and July.

#### STAFF

Although Jon Conte has resigned he carried out the role of our systems worker well and has developed many areas for our continued support. This clearly indicated the need for at least one full time member of staff to operate out of the Freyer Street Centre.

CONSOLIDATION TIME

During 1978 we consolidated our operations at the time of the robbery to three locations only -

- .. 3 Freyer Street, Williamstown North
- .. Altona City Library
- .. Ted Pecks

The Directors believed that greater flexibility and efficiency would be obtained through a more centralised base of operations. Francis Street, although it offered larger premises, was not convenient to public transport and did require massive renovations to the space in order to meet our needs.

The robbery did provide the means to update a great many items of equipment which had been part of our initial grant and which was badly worn.

EQUIPMENT

The 1977-8 grant enabled the co-operative to move in two directions:

1. Firstly to purchase a reliable editing system that despite Editape, had not been previously available. The National 3160 fill this capacity admirably.
2. Replacement of one of our Sony portapak's meant good pictures for production work.
3. Microphones, cables, Rf converters, all made life a little easier in many productions.

The Normende Flying Spot Scanner for Super 8 film did not measure up to the expectations many of the members believed it would. Technically this type of equipment leaves a lot to be desired.

The insurance on the stolen equipment has enabled us to update much of the stock but meant much of our planning had to be shelved to become operational again. A general appraisal of our loss and the alternatives open, meant a solid re-think of our operations,

Out of these difficult times we have submitted in this coming grant period - first, equipment to carry on some of our previous plans, and secondly, compliment our existing equipment stock.

New items are listed below:-

- (a) National ½" colour editing system (3160)
- (b) Four National Portapaks
- (c) Three National Studio cameras and cables
- (d) 3 ITE Studio Dollies (fluid mount)
- (e) GITSO fluid head tripods
- (f) 2 Colour Receiver Monitors
- (g) Four Black & White receiver monitors for Portapaks,
- (h) Two National special effects generators
- (i) Sony Editape system
- (j) 6 channel microphone Mixer 8 channel Mixer
- (k) Associated microphones/cables, etc.



THE VAN

The purchase of the Mobile Recording Van (TOYOTA HI LUX) has long been strongly in the minds of the co-operative. General agreement expressed the need for a van in preference to a Caravan, as it overcomes the problems associated with towing and security.

The van provides the Western Suburbs, and Melbourne as a whole, with the only self-contained studio facility for productions away from our base.

The van is fitted out with the following:-

1. 3 Black & White Studio Cameras
2. National Special Effects Generator
3. 3 ITE Studio Dollies
4. 6 Channel mixer
5. U-Matic Recording

The van provides full power connections, roof rack camera platforms for two cameras, a functionally designed layout for simple operation. It is hoped that in twelve months time we will be able to report most favourably on the vans operation.

\*\*\*

## OPERATIONS FROM ALTONA CITY LIBRARY

During 1977/8 Altona City Library continued its association with WESCOM in the provision of access video for the community. The library continued to provide basic portapak units and replay system, together with introductory lessons on the use of this equipment for the creative expression and advantages offered by this medium.

Our figures indicate a noticeable increase in the amount of loans as compared to last year. This increase can be attributed to the existence of a paid member of WESCOM, for whilst the efforts of volunteers have been and continue to be commendable, the employment of a paid video worker has been of great benefit to WESCOM and the Library.

The location of equipment at the library has been continually upgraded, maintenance has been carried out effectively and promptly and communication within the Wescom network improved.

The equipment has been used by new and old members, several new video classes have started and moved on to more advanced work under the guidance of Wescom's worker.

To summarise, in 1977/8 we have seen an improvement in service at this outlet and increased use has also been observed. It is anticipated-that during 1978/9 the employed video worker may be able to assist in the work of informing a greater number of people in the community about the possibilities of community television.

We take this opportunity to thank the library staff for their co-operation and assistance during the past year.

## MAJOR PRODUCTIONS

Major productions during the last year were restricted by the robbery in December, however, the following programmes were completed:-

1. Williamstown Summer Festival
2. Altona Recreation Day
3. Diabetics Lectures - Western General Hospital
4. Jane Eyre (Drama) (CLC School, Eltham)
5. Documentary (3CR) Radioathon Day,
6. Judging of Fressian Cattle (Fressian Farmers Assoc)
7. Carpendiet - History of a town
8. Western District Sheep Dog Trials

These are the major productions for the year. We hope to expand this programme and increase the number of participants.

THE FUTURE (1978/9 SUBMISSION)

The future twelve months of the Co-operative can be categorised under the following headings.

1. Maintenance of our existing programme of activities (including greater emphasis on training programmes).
2. Greater development of income earning areas of our operation to encourage greater self-sufficiency.
3. Movement into new areas of the media and medium, with two aims -
  - (a) Meeting the needs in areas which are presently absent or lacking in the Western Suburbs of Melbourne.
  - (b) Developing financially productive areas and services to offset part of our operating costs.

MAJOR AREAS OF THE 1978/9 SUBMISSION

A. OPERATING EXPENSES

1. Staff
2. Administration
3. Maintenance
4. Insurance

Total =

B. EQUIPMENT

1. Colour Camera
2. 1" Editing
3. Microphones
4. Test Pattern Generator

Total =

## INCOME EARNING POTENTIAL

The Co-operative is currently reviewing its income earning potential with a view to recovering some of the operating costs of the co-operative. We find ourselves in the situation of not having the type of equipment that will attract a great deal of income. The basis of our submission is to attract customers in the colour recording and editing areas. Our past experience indicates that this area is potentially lucrative. We believe the following items will attract reasonable returns.

1. Recording of original material on our own colour camera. Material for editing on either ½" or 1".
2. Editing of material on either 1" or three-quarters.
3. Borrowing charges have not been made on members in the past because it was our aim to keep the cost to members at the lowest possible level. However, a charge for the use of portapaks will be closely investigated by the directors.
4. The acquisition of an eight-channel microphone mixer will have great attraction to sound enthusiasts. The area of sound equipment borrowing is limited in Melbourne and is an area- we will hope to move into.
5. Productions from our mobile van.

The Co-operative at its next meeting, is to consider charging a fee for certain items of equipment as a means of covering some operating costs.

The following will be considered:-

<u>ITEM</u>	<u>MEMBERS</u>	<u>NON-MEMBERS</u>
Portapak	Free	\$5.00
B/W Deck & Monitor	Free	\$5.00 -
Editing	Free	\$10.00 per day
U-Matic Recorder	\$5.00	\$20.00
Van Hire	\$10.00	\$20.00
Mike-mixers - 8 channel	\$10.00	\$20.00
Colour monitor	\$10.00	\$20,00

Apart from equipment charges, we aim to develop by means of our submission, the production of colour programmes for a production fee.

Workshops for outside groups as well as members is presently being considered.

#### FUTURE PROGRAMME PRODUCTION

It is difficult at this time to give a complete list of productions currently being considered. However, we have negotiated for the following:-

1. Altona Recreation Day 1979
2. Williamstown Summer Festival 1979
3. Training Tapes - Toyota, Australia
4. Cattle Judging - Melbourne Show 1979
5. Television - An Historical look at Williamstown
6. Promotional Activities with Altona Gate Shopping Complex

## CONCLUSION

The coming year is a year-of challenge for the members of the Western Communications Co-operative.

With the success of our submission, we will be able to consolidate our administration and move into full colour production for the first time. These possibilities are truly a challenge for us all.

We look forward to the continued support of all sections of the community and to the Australian Film Commission who fund the programme.

WESTERN COMMUNICATIONS. EQUIVILENT FULL DAYS OF LOANS

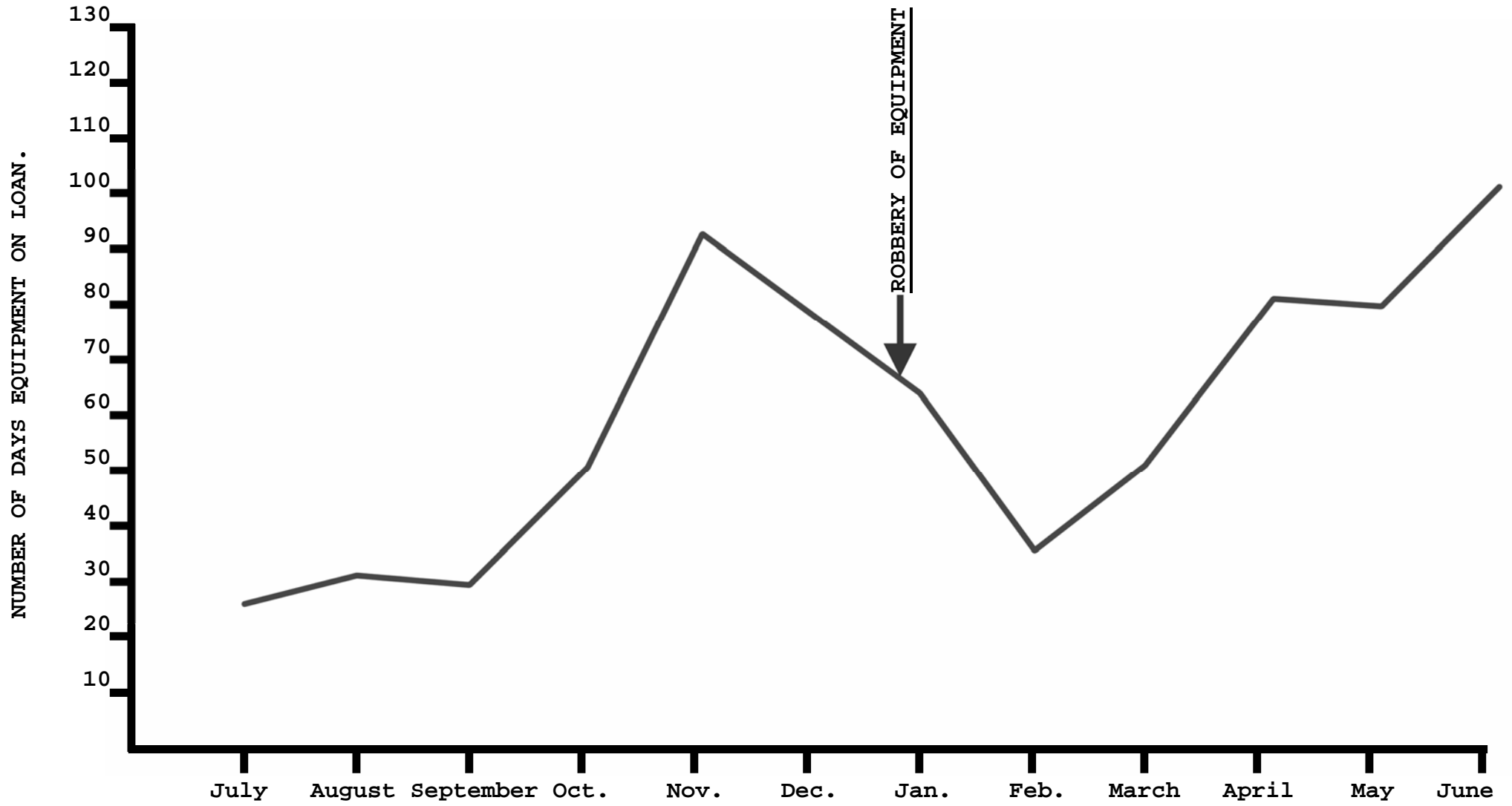



WESTERN COMMUNICATIONS CO.OP LTD.  
STATEMENT OF RECEIPTS & EXPENDITURE  
YEAR ENDED 30th JUNE, 1978

Receipts

Grants received - Aust. Film Commission	\$41000.-	
Insurance Claim paid	6791.-	
Borrower's Registration Fees	333.-	
Videotape Sales	302.38	
Equipment & Studio Hire	137.-	
Sundry Receipts	69.-	
Productions	62.-	
Membership Fees	10.-	
Training Fees	15.-	
Bank Interest	<u>436.34</u>	49155.72

Expenditure

Purchase New Equipment	16758.31	
Wages paid	15796.57	
Purchase Toyota Van	4500.-	
Videotapes	1830.52	
Insurances	1304.29	
Equipment Service	1007.12	
Administration Costs	957.10	
Equipment Spares	662.62	
Security Alarm	666.-	
Petty Cash	589.52	
Telephone	390.67	
Special Projects Fund	271.11	
Travelling Expenses	206.68	
Office Supplies & Stationery	152.27	
Postage & Printing	130.21	
Sundry Expenses	150.56	
Typewriter Service	62.50	
Advertising	40.-	
Post Box & mail	<u>29.50</u>	<u>45505.65</u>
	<u>SURPLUS</u>	<u>\$3650.07</u>

RECONCILIATION

Cr	Balance as per Books 30.6.77	\$9177.52
	Surplus for Year	<u>3650.07</u>
		<u>\$12827.59</u>
	Opening Balance CR 30.6.78	9177.52
	Receipts for Year	<u>49155.72</u>
		58333.24
	less Payments for Year	<u>45505.65</u>
		<u>\$12827.59</u>
	Balance as per Bank 30.6.78 CR	13696.04
	Add Deposits not yet credited	<u>8. -</u>
		13704.04
	Less Unpresented Cheques	
	No. 009 423. -	
	No. 001 453.45	
		<u>876.45</u>
CR	Balance at 30.6.78	<u>\$12827.59</u>

Audited and found correct.

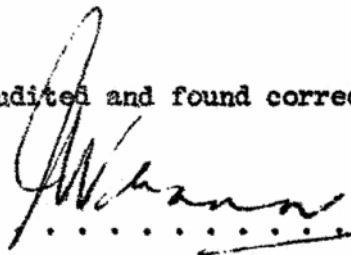

JAMES W. MANN.

AASA LCA

15.8. 1978